

# The Australian Light Horse Association Ltd.

## ~ ASSOCIATION CUP ~

### EVENT 5

#### SKILL AT ARMS

##### GENERAL

Although these rules have been based on those of the Australian Tentpegging Association, ONLY the following rules contained in this document are to be used during the Association Cup competition.

Each member of the section will run the course individually and the combined totals of each member's score will be the total score for that section.

In the event of a tie, the fastest total time for the sections wins.

##### LAYOUT

1. The course should be set up as per "*Layout of Skill at Arms Course*" diagram.
2. A standard course is 130m long and 20m wide.
3. The course could be shortened to 100m should space not be available.
4. For the first leg, position the three balloon holders and the weapon holder in line and at the correct intervals. Then move the 2nd balloon holder to the left of the line by 1.5m. The jumps can then be placed on the ends of the balloon holders.
5. For the second leg, position the two Effigy Heads and the centre of the dummy target in line and at the correct intervals. Then move the 2nd Turks Head to the left of the line by 1.5m.
6. For the third leg, position the two rings on the Gallows and the peg in line and at the correct intervals. Note that on the "*Layout of Skill at Arms Course*" diagram that at the 60m mark, the second jump, the first Gallows and the second Turks head are in a line across the course.
7. Cones should be used to mark the start and end of each leg

## **DRILL PROCEEDURES**

The following are the positions of weapons that are referred to in this event.

### **SWORD POSITIONS**

**RECOVER:** The blade is perpendicular, edge to the left, upper part of the hilt opposite the mouth, elbows close to the body.

**CARRY:** The forearm is horizontal, hand in front of the elbow, elbow close to the body. Blade is perpendicular, edge to the front. First, second and third fingers and thumb gripping the handle under the resistance piece, the little finger behind handle to steady it. Wrists resting on the thigh and the pommel pressed against the inside of it. Upper part of the arm is close to the body with the elbow lightly touching the hip.

**SLOPE:** The forearm is horizontal with the upper arm perpendicular. The back of the blade of the sword rests lightly on the right shoulder, midway between the neck and the point of the shoulder. The guard rests on the hand with the little finger still in rear of the handle.

**DRAW SWORD:** Pass the right hand smartly across the body over the bridle arm and draw out the blade so as to rest the hilt on the bridle arm. Grasp the handle with the right arm close to the body, shoulders square to the front. With an extended arm, draw the sword slowly from the scabbard in rear of the left shoulder and bring it smartly to the RECOVER. Then lower the sword smartly to the CARRY position.

**PRESENT:** The sword blade is extended to a horizontal position at shoulder height. The knuckles of the hand are pointing upwards and the sword edge is pointing outside to the right. The sword is rotated 90 degrees to the right, pause, engage the target.

**ENGAGE:** From the PRESENT, the sword is swung horizontally onto the shoulders at the base of the neck with the blade edge to the rear and the point to the left.

### **LANCE POSITIONS**

**TRAIL:** The lance is carried at the balance, with the point lowered to the left front. The tip should be level with the horses near ear and the knuckles down and the right elbow slightly forward.

**CARRY:** The lance is held in a vertical position with the butt of the lance on the riders boot or in a lance bucket. The hand is level with the shoulder with the back of the hand to the front.

**PRESENT:** The lance held in the vertical position. The arm is extended forward and held parallel to the ground, thumb vertical to the rear of the lance.

**ENGAGE:** From the PRESENT, the point of the lance is lowered to the front in an even sweep so that the point reached the level of the peg an instant before it strikes. At the same time, the rider is leaning slightly to the off side with the right hand below the level of the knee. The back of the hand is inclined outwards and the thumb is along the shaft of the lance.

**STRIKE and RECOVER:** At the instant the peg is struck, the eye will be on the peg and the point of the lance. As the peg is passed, the arm is kept straight and the lance is allowed to swing back to a horizontal position, pointing to the rear and level with the right shoulder. The eyes are still on the point of the lance. This will cause the head to turn out of the path of the butt of the lance which saves the back of the head from being struck. The lance is then swung forward in a graceful underhand sweep to a vertical position as in the **PRESENT**. It is then snapped back to the **CARRY** position.

## **EVENT DRILL DESCRIPTION**

1. The following is the sequence of drill moves that must be used during the competition.
2. As the rider enters the course, he places his lance at the start of the third leg. The rider then waits at the Start Line with pistol held in a vertical position with the right elbow against his side, when he receives the "All Clear" salute from the judge he will salute the judge and when acknowledged will then gallop down the first leg of the course.
3. At the first jump, the balloon is "shot" on the right hand side of the rider using only one jab per balloon. One refusal will be allowed on the first jump **ONLY**. A horse ridden around the jump constitutes a refusal.
4. The balloon on the second jump is on the left hand side of the rider and is "shot" by bringing the riders right hand over the front of his body. The third balloon is "shot" on the right hand side of the rider.
5. The rider places the pistol into the weapon holder, he then **DRAWS SWORD** and continues to the second leg with the sword at the **SLOPE**
6. The rider travels the first 15m of the second leg at the **SLOPE**. At the Present flag (A) the sword is brought from the **SLOPE** to the **PRESENT** to the **ENGAGE** then the sword is swung horizontally onto the shoulders at the base of the neck, blade edge to the rear.
7. At the engage flag (B), the sword is brought out horizontally to the right, blade forward and right hand level with the shoulder to cut the first Effigy Head at the neck with a slight forward sweep on the right hand side
8. Bring the sword to left side of the body, roll the wrist and knuckles up blade facing forward, forearm horizontal and level with the shoulders. Cut the second Effigy Head at the neck with a slight forward sweep on the left side
9. Bring the sword back to the **PRESENT** with knuckles up and then to the **ENGAGE**

**NB** If the rider stops to place the pistol into the weapon holder then the draw the sword whilst at the halt it is unachievable to make the course with the 60seconds

10. Strike the target on the Dummy and leave the sword in the Dummy. By having the sword with the blade vertical, it allows the body to rotate as you pass the dummy and not unseat the rider should the swivel mechanism fail.
11. Continue to the end of the second leg and after rounding the flag, continue to the lance. The rider picks up the lance that is stuck in the ground at the start of the third leg and brings it to the **TRAIL**
12. On reaching the flag (A) the lance is brought to a horizontal position, under the right arm, close to the body with elbow bent.
13. On reaching the flag (B) the lance must be rolled forward to the extent of the arm, with the lance resting on top of the arm. The back of the hand faces the left. Engage both rings and then lower the lance to ENGAGE the peg. RECOVER and ride over the Finish Line, with the lance at the CARRY

## **RULES**

1. Timing starts when the rider leaves the Starting Line. There is a time limit of 60 seconds for this event. Time faults will be accumulated at 1 fault per second over the 60 seconds.
2. The rider is only allowed 1 refusal on the first jump. A refusal on the second jump results in disqualification.
3. The rider will incur a 3 point penalty loss of Drill Points if the pistol is not placed in the weapon holder or if the weapon holder is knocked over. Points are not scored if the Effigy is not cut on the neck.
4. The sword does not have to remain in the Dummy to score points. However, if the sword is thrown at the dummy, a 3 point penalty loss of Drill Points is incurred for a dropped weapon.

## **SCORING**

The scoring for each element is as follows:

1. Jumps 3 points each.
2. Balloons 6 points each
3. Weapon into the weapon holder 3 points. Effigy 6 points each – neck strike only
4. Dummy 6 points for a bull's eye, 3 points for anywhere else on the target
5. Rings 6 points each
6. Peg 2 pts Strike – Peg struck but no removed from the ground
7. 4 pts Draw – Peg removed but not carried for more than 20 m
8. 6 pts Carry – Peg removed and carried for more than 20m
9. Drill points are awarded on general horsemanship, use of weapons and style
10. 1st Leg 4 points
11. 2nd Leg 4 points
12. 3rd Leg 4 points
13. Penaltys
14. Time

- a) Loss of weapon 3 points
- b) Fall of a rider Disqualification
- c) Off Course Disqualification

## **DISARMED COMPETITOR**

1. A disarmed competitor shall be one who loses his weapon at any time from the commencement of the run, until the completion of the round.
2. They will not be rearmed before the completion of the round but may score points prior to being disarmed or during the process of being disarmed.
3. They will be penalized for faulty weapon handling with an automatic loss of three drill points. A competitor who breaks his weapon cannot be re-armed during the round and will not be granted a re-run

A competitor who is dismounted whether by his falling or stumbling etc at the commencement or during the run is disqualified IE: loss of control of the horse. Also subject to a medical check

## **DISQUALIFICATION**

1. If in the opinion of the judge, a competitor mistreats his horse, that rider may be disqualified from the competition.
2. If a rider runs off the course (travels on the wrong side of an element) he will be disqualified and must leave the course immediately.
3. If in the opinion of the judge, the rider does not have control of the horse and it is dangerous to continue, that rider may be disqualified from the competition.
4. If the rider has a second refusal on the first jump or a first refusal on the second jump, that rider is disqualified.
5. The Judge will notify the competitor that he has been disqualified by cracking a whip, ringing a bell or some similar device. The competitor MUST immediately leave the course.

## **EQUIPMENT**

**SADDLES:** The rider must use a UP military saddle with a military bridle and bit.

**JUMPS:** These consist of three hay bales per jump. There should also be a ground pole on the leading side of the jump.

**BALLOON HOLDER:** As per attached sketches.

**EFFIGY HEAD:** As per attached sketches.

**DUMMY:** As per attached sketches.

**GALLOWS:** As per attached sketches.

## **PEGS**

1. Fluted core board pegs should be used and can be made of layers glued together with min total thickness of 10mm. with corrugations running vertically.
2. The dimensions of the pegs are 30 cm. long, 10cm. thick and 7.5cm wide.
3. The pegs are driven into the ground at an angle of 60 degrees from horizontal, with 25 cm. of the peg showing above the ground level.
4. The face of the peg must be painted white.

## **WEAPONS**

**LANCE-** The lance used in competition shall not be shorter than 2.5m and shall not exceed 2.75m. Lances can be of any material with a smooth metal point, without serrated or sharp edges. Grips are permitted.

## **SWORDS**

1. The sword shall be the 1908 pattern trooper's sword.
2. Length: 89cm in blade length, with an overall length of 1.08 m.
3. The sword must be carried at the rear nearside of the saddle attached to a shoe case.

**BAYONET-** 1903 Pattern with scabbard worn on the left side fixed to the belt.

**PISTOL-** The pistol is to be a maximum of 30 cm from point to hammer, with a point a maximum of 3mm diameter.

## **GROUND CREW**

1. Resetting the course will be carried out by ground crew. The judge is responsible to see that this is carried out correctly.
2. Ground crew in the centre of the ring shall be limited to an absolute minimum.
3. It is recommended that there is sufficient ground crew so that each member of the ground crew has only has to reset one element of the course. This will greatly reduce the time required to run this event should there be a considerable number of competitors.

ALPHA ASSOCIATION CUP

# Skill at Arms Course and Equipment

## Layout of Skill at Arms Course

130 m x 20 m  
Not to Scale

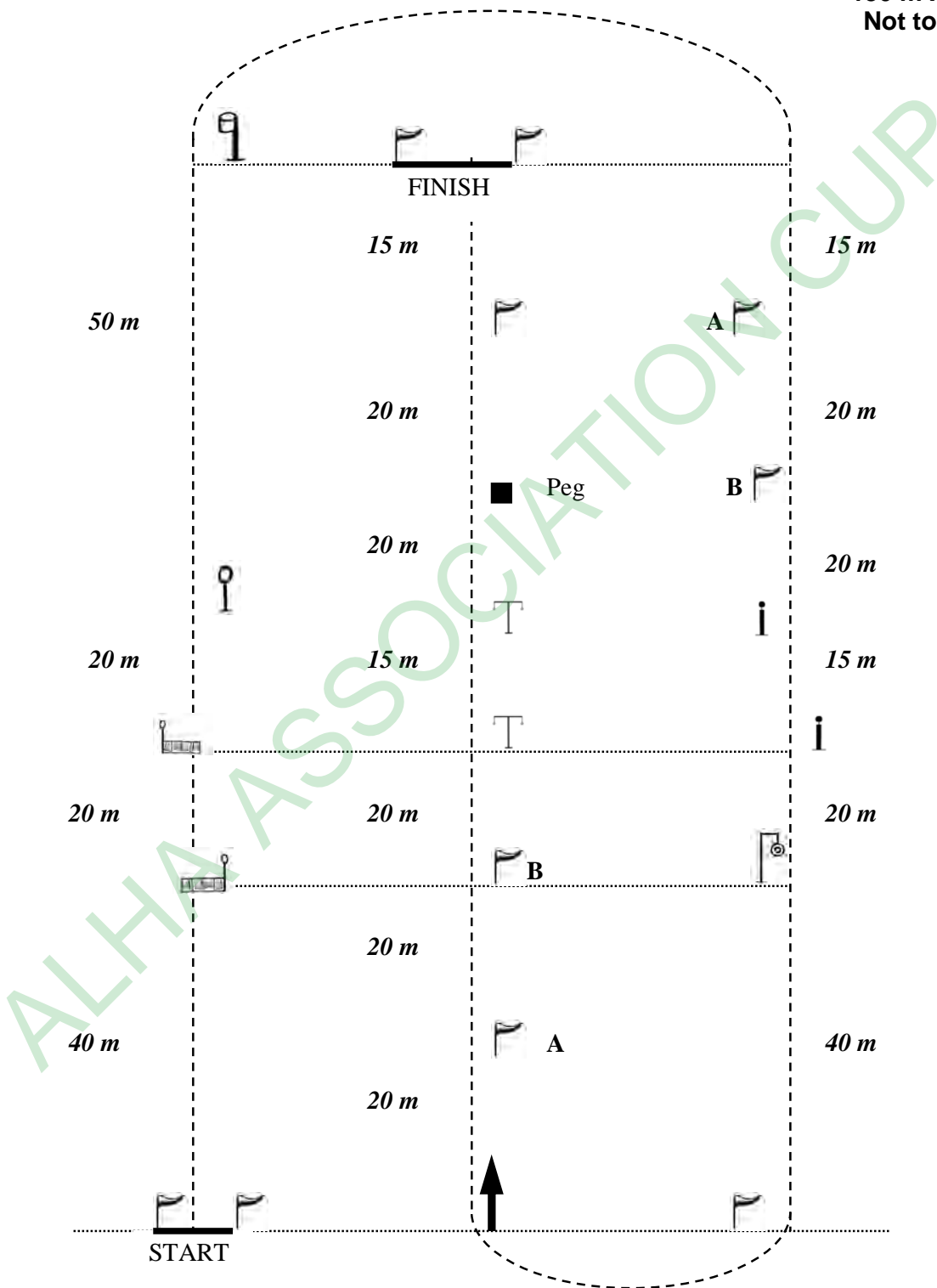



# SKILL AT ARMS

## EQUIPMENT DIMENSIONS

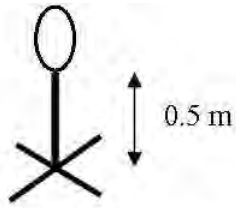

**SHORT BALLOON  
HOLDER**

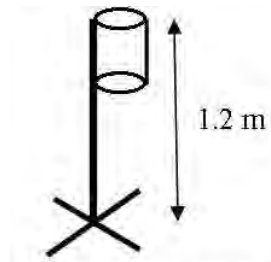

**WEAPON HOLDER**

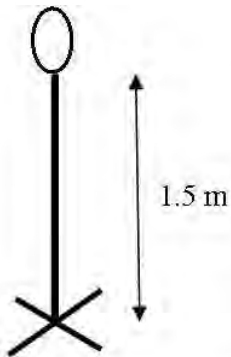

**TALL BALLOON  
HOLDER**

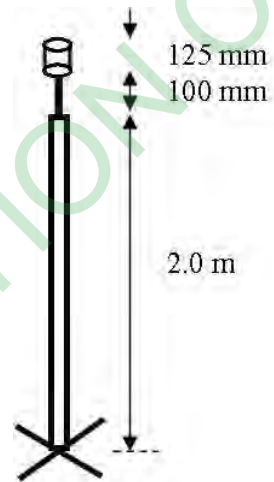

**EFFIGY**

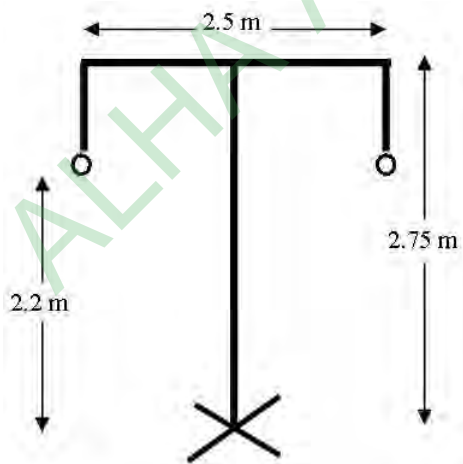

**GALLOWS**

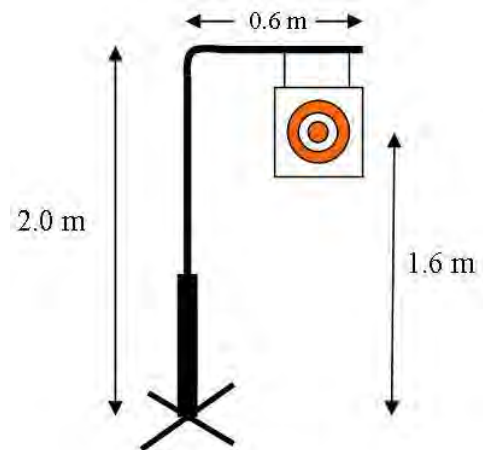

**DUMMY**

# SKILL AT ARMS

## MATERIALS LIST

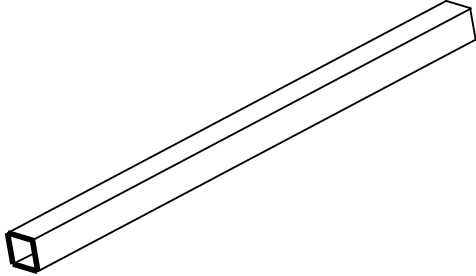

### Cut Lengths of 25 x 25mm

1 x 0.50 m	Short Balloon	0.50
2 x 1.50 m	Tall Balloons	3.00
1 x 1.20 m	Weapon Holder	1.20
2 x 1.88 m	Effigy Heads	3.76
4 x 1.36 m	Gallows Posts	5.44
4 x 1.275 m	Gallows Cross Arms	<u>5.10</u>
		<b>19.00 m</b>

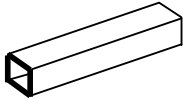

### Cut Lengths of 32 x 32mm

2 x 600 mm	T Pieces	1.20
2 x 450 mm	Gallows Post Joiner	0.90
10 x 300 mm	2 x T Pieces	3.00
	8 x Base Plates	<u>          </u>
		<b>5.10 m</b>

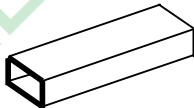

### Cut Lengths of 50 x 25mm

6 x 650 mm	6 x Small	3.90
12 x 200 mm	Base Plates	2.40
2 x 850 mm	2 x Large	1.70
4 x 400 mm	Base Plates	<u>1.60</u>
		<b>9.60 m</b>

# SKILL AT ARMS

## CONSTRUCTION DETAILS

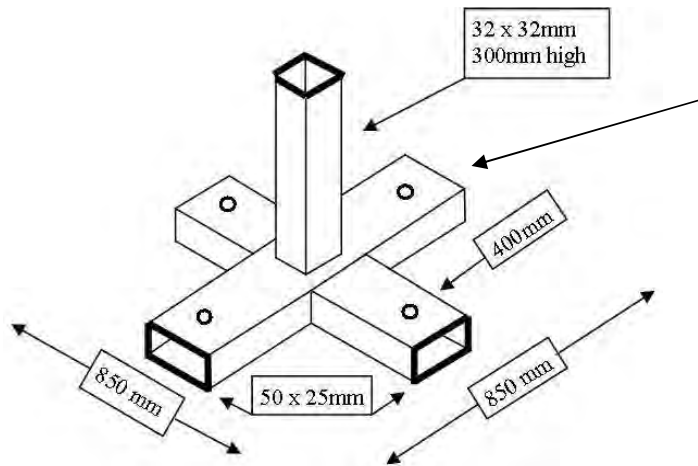

**LARGE STAND**

Drill 13 mm holes to take 10mm diameter tent pegs to secure stands to the ground

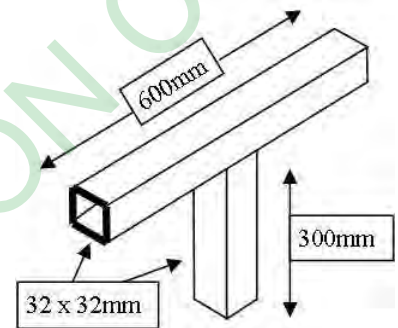

**GALLOWS "T" PIECE**

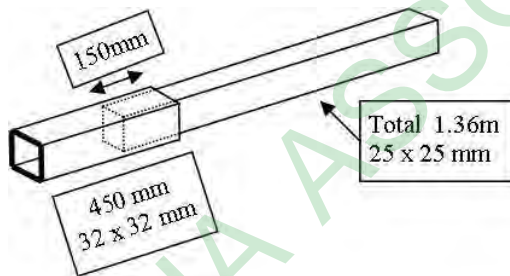

**GALLOWS EXTENSION**

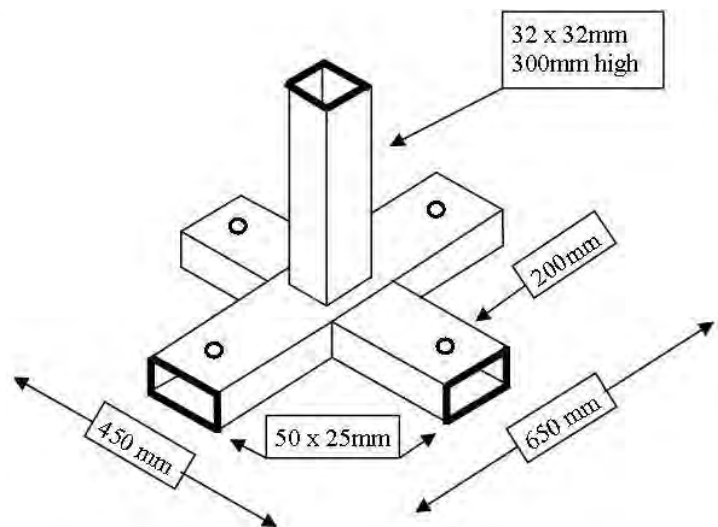

**SMALL STAND**

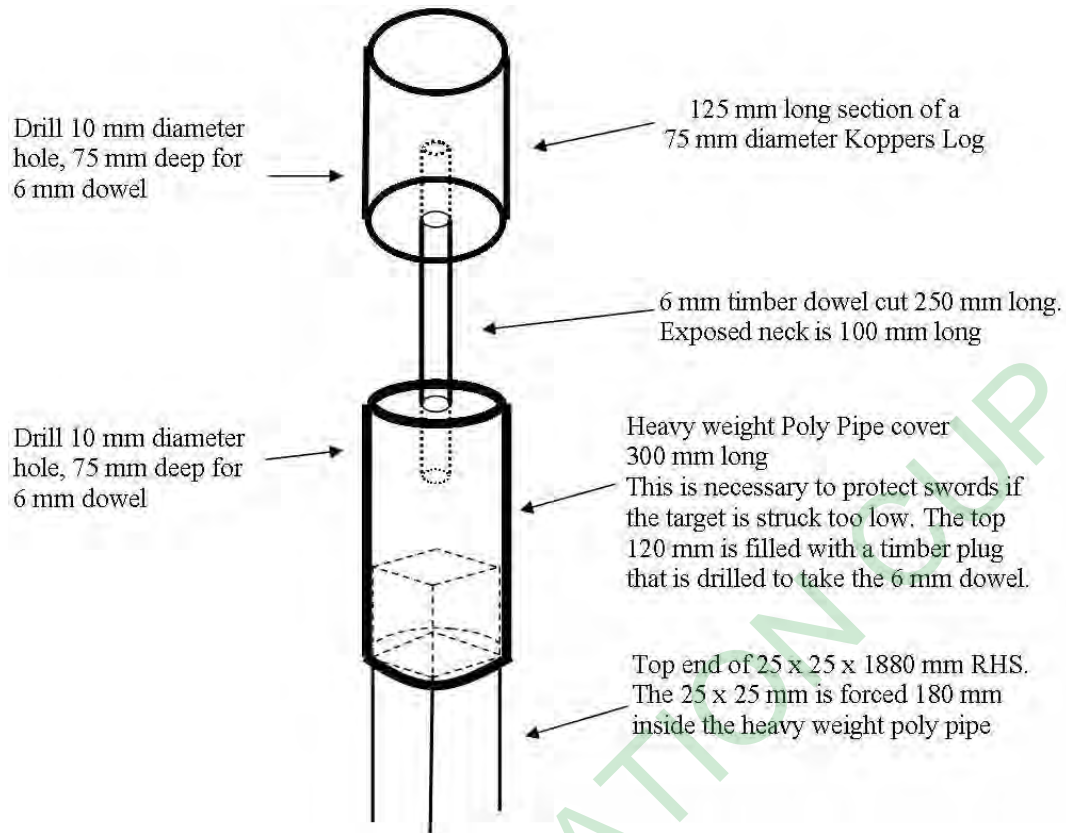

### DETAILS OF TOP OF EFFIGY HEAD

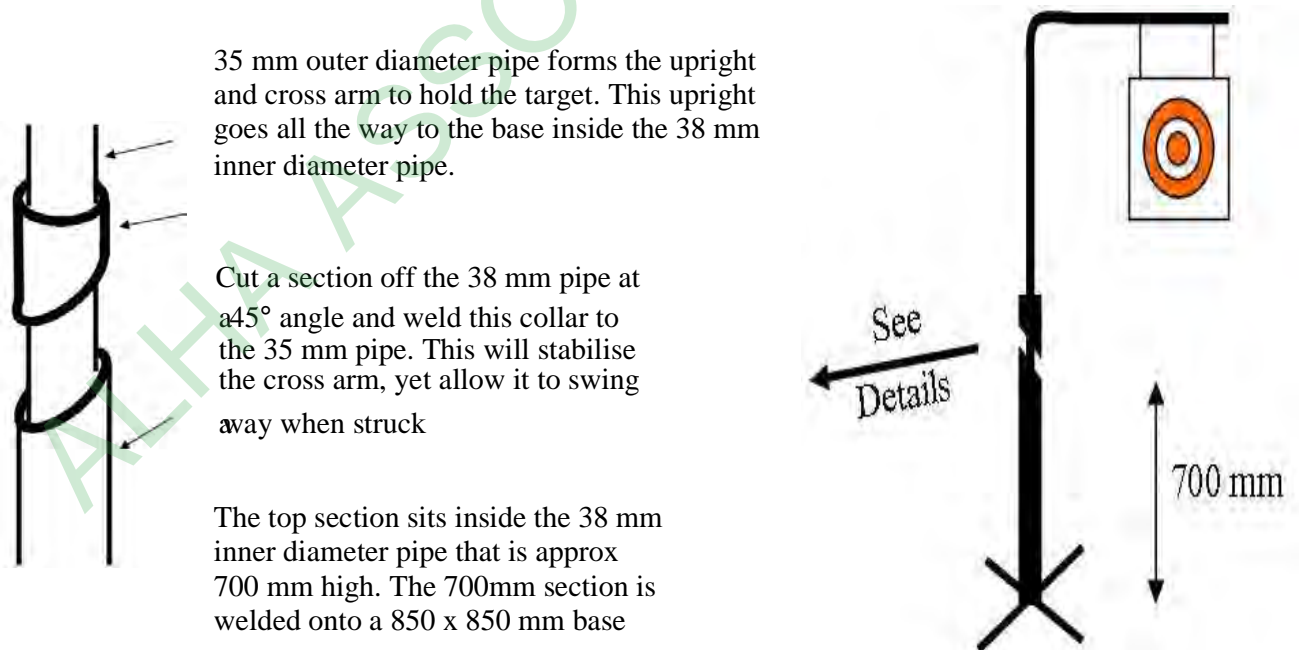

### DETAILS OF DUMMY SWIVEL MECHANISM

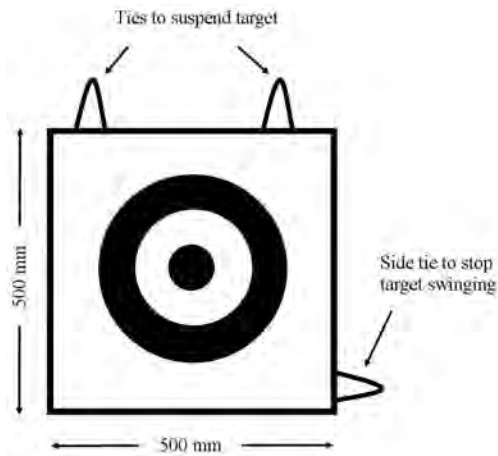

- The target can be made by sewing a biscuit of hay inside a feed bag.
- The diameter of the centre ring (bullseye) of the target is 80 mm. The white ring and the outer black ring are 60 mm wide
- The centre ring is 1.6 m above the ground.
- The target can be fixed to the dummy frame with the top ties and a side tie to stop the target swinging.

### DUMMY TARGET DETAILS

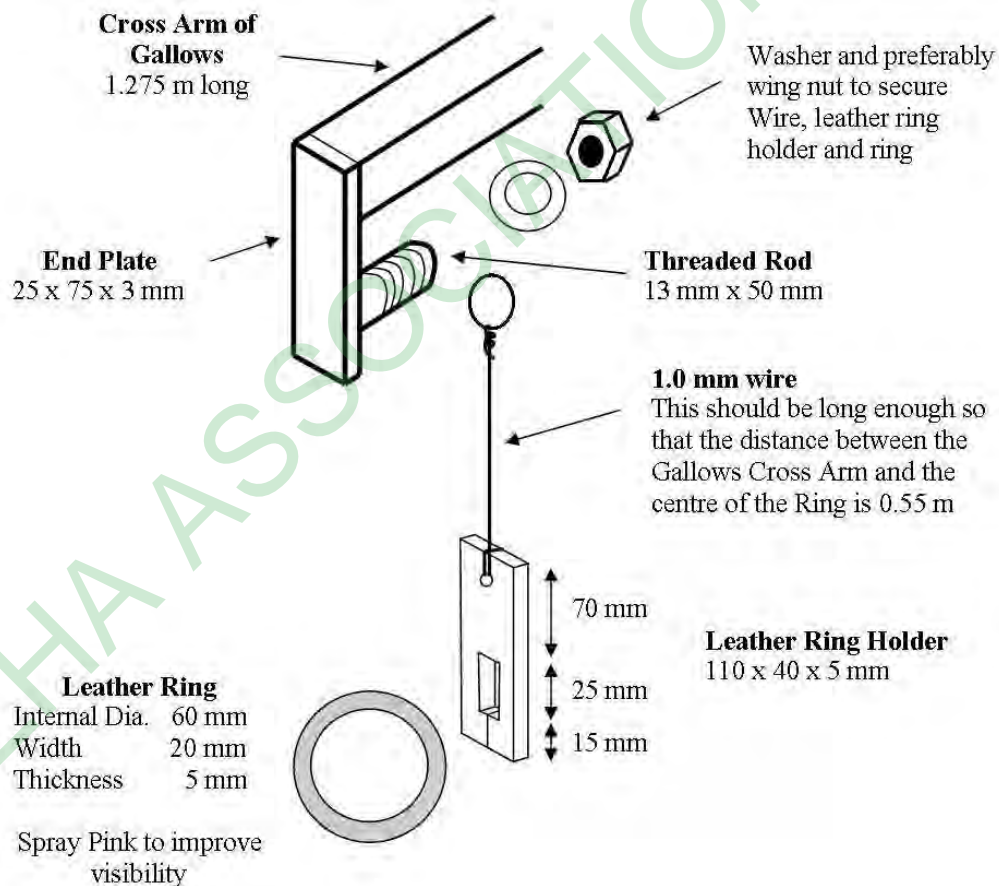

### DETAILS OF END OF GALLOW'S CROSS ARM

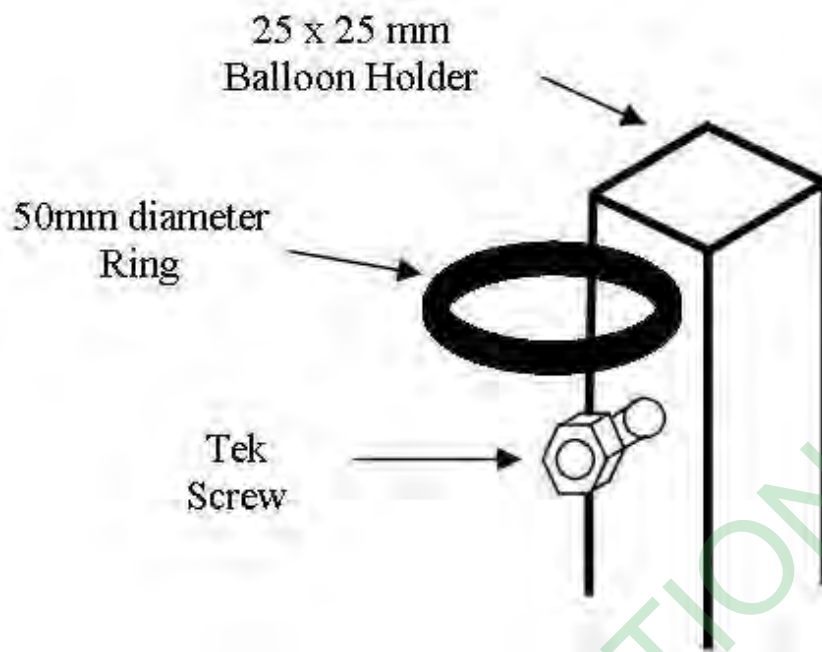

**DETAILS OF BALLOON  
HOLDER TOP**

ALPHA ASSOCIATION CUP